

CSC4200/5200 – COMPUTER NETWORKING

ETHERNET AND WIFI

Instructor: Susmit Shannigrahi
sshannigrahi@tntech.edu

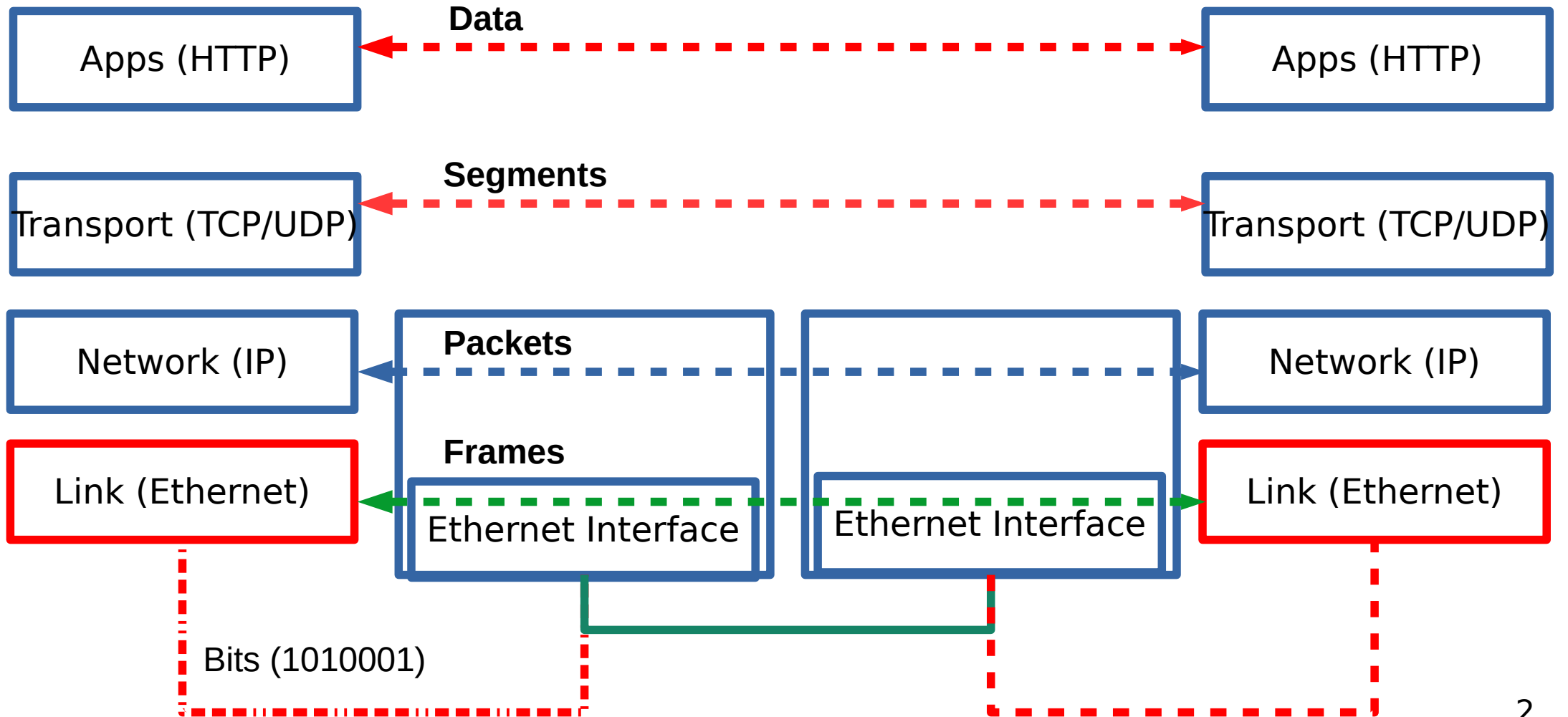

So far.



- We have connected two machines using point to point wires
 - Encoded bits
 - Sent bits as Frames
 - Caught and corrected errors
 - Tuned efficiency and reliability using sliding window
- What happens when there are more than two machines?

Map of Hawaii

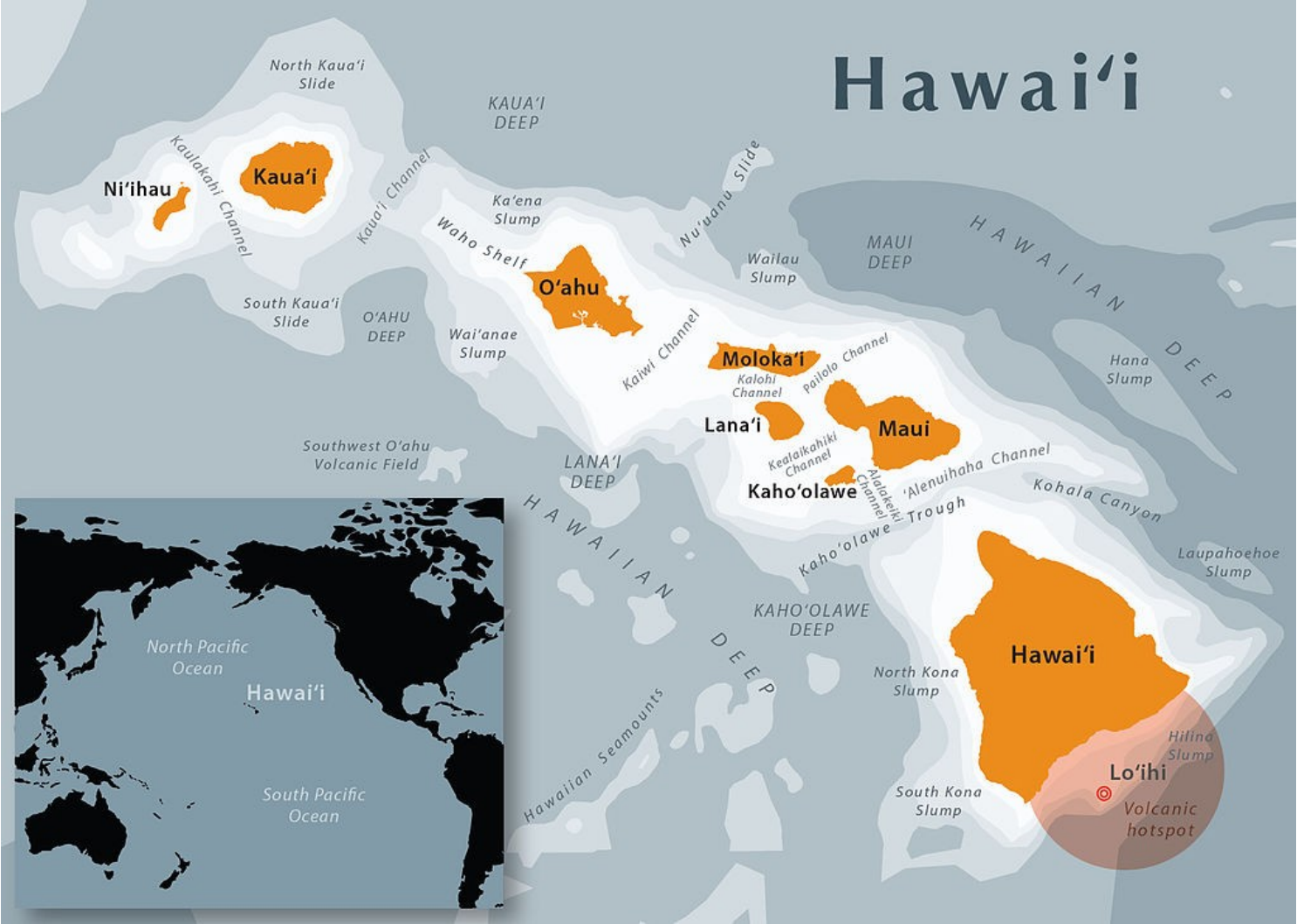

wikipedia

AlohaNET

- Connect University of Hawai‘i’s computers using wireless radio to main campus in Oahu
- Random access to radio channel
 - If you have data, send
 - If you hear someone else, collision! Resend “later”
- Fixed frequency channels
 - Shared medium

Abramson, Norman. "Development of the ALOHANET." IEEE transactions on Information Theory 31.2 (1985): 119-123.

<https://www.eng.hawaii.edu/about/history/alohanel/>

Pure Aloha

- If you have data to send, send it.
- While transmitting, if you hear from anyone else, collision!
 - Try retransmitting later.

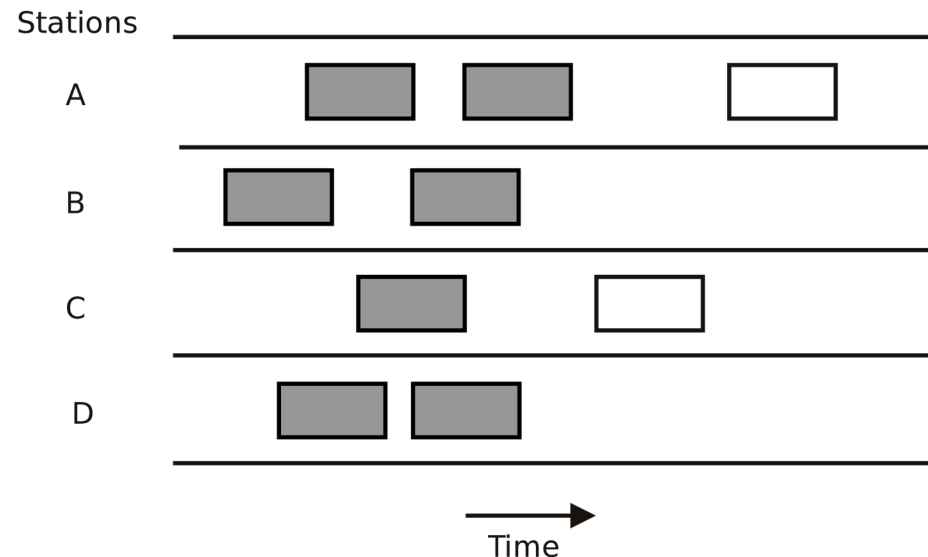

Slotted ALOHA

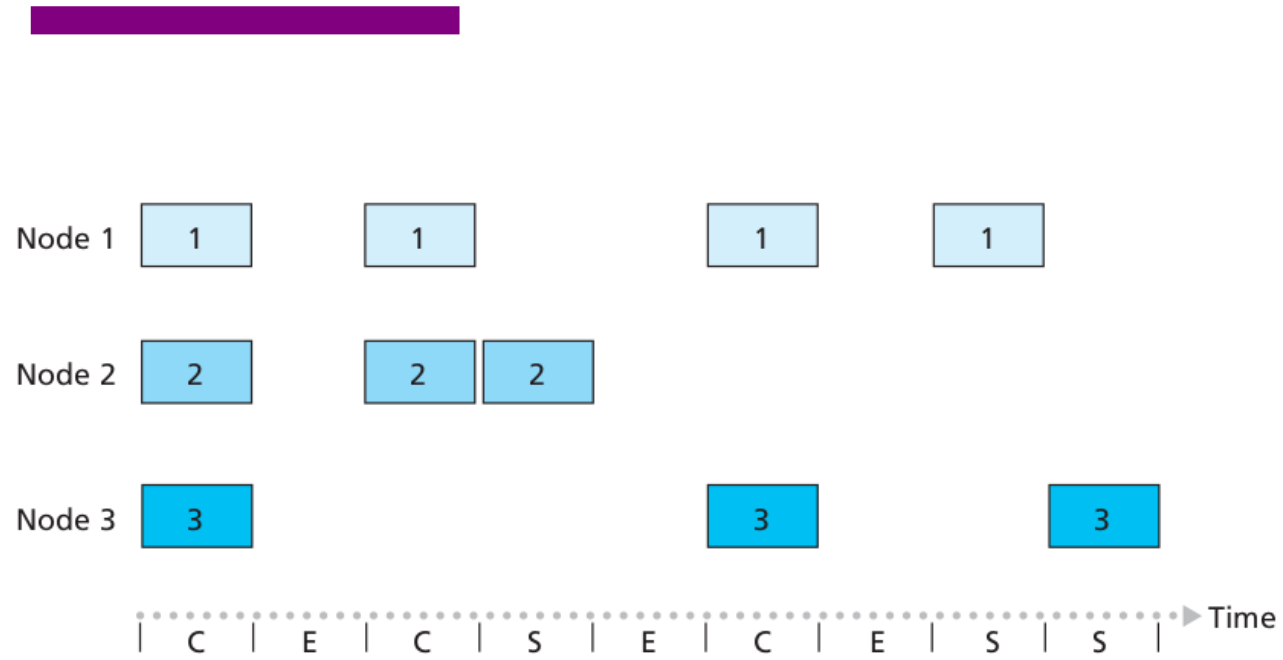

Slotted ALOHA - Problems

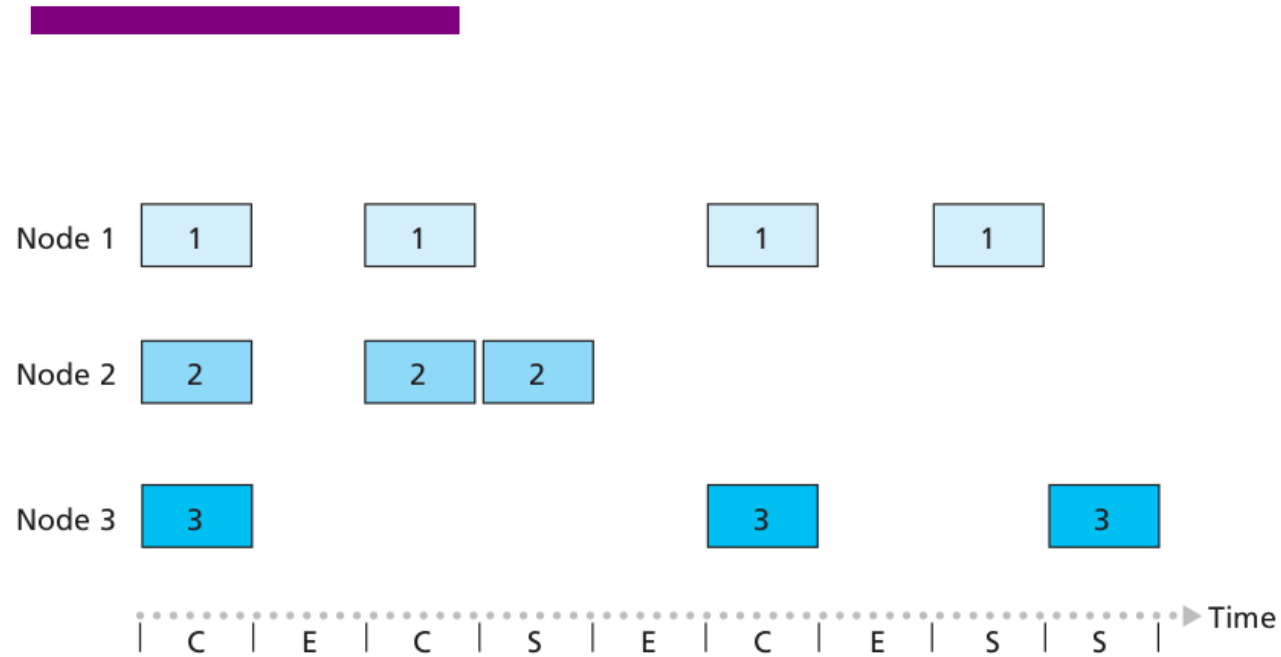

- Wasted slots
- Idle slots
- Need to sync
- Low efficiency

CSMA – Improvement over Aloha

1) Carrier Sense

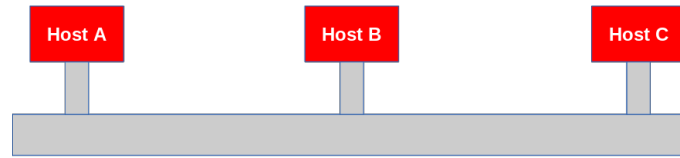

2) Multiple Access

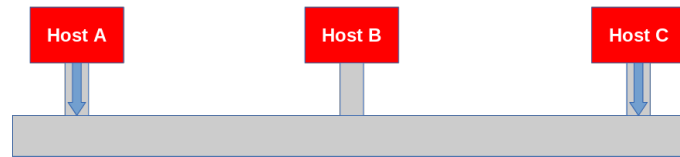

- Listen first -
 - If channel is idle, send
 - If channel is busy, wait and send later
- Propagation delay
 - You may not hear others before it's too late!

Ethernet – Wire as Shared Medium

- Most successful local area networking technology of last 20 years.
- Developed in the mid-1970s by researchers at the Xerox Palo Alto Research Centers (PARC).
- For alohanet the medium was the atmosphere, for ethernet, coax cables

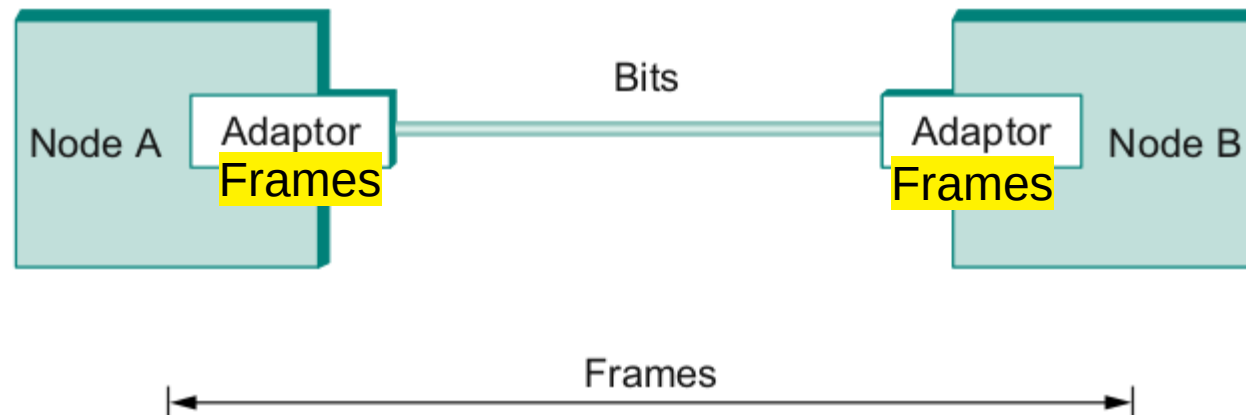

Ethernet – IEEE Standard 802.3

- How to allow many adaptors to send frames over the wire?
 - Access protocol

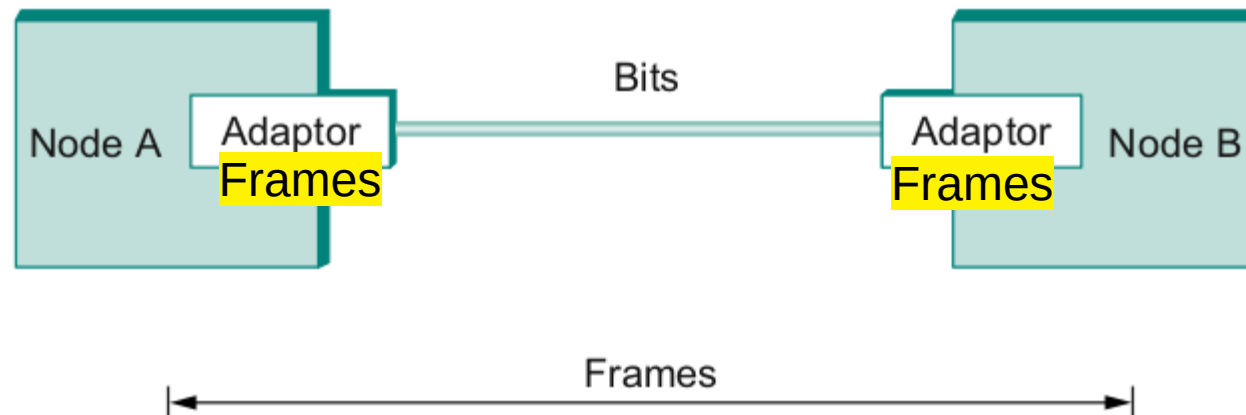

Ethernet

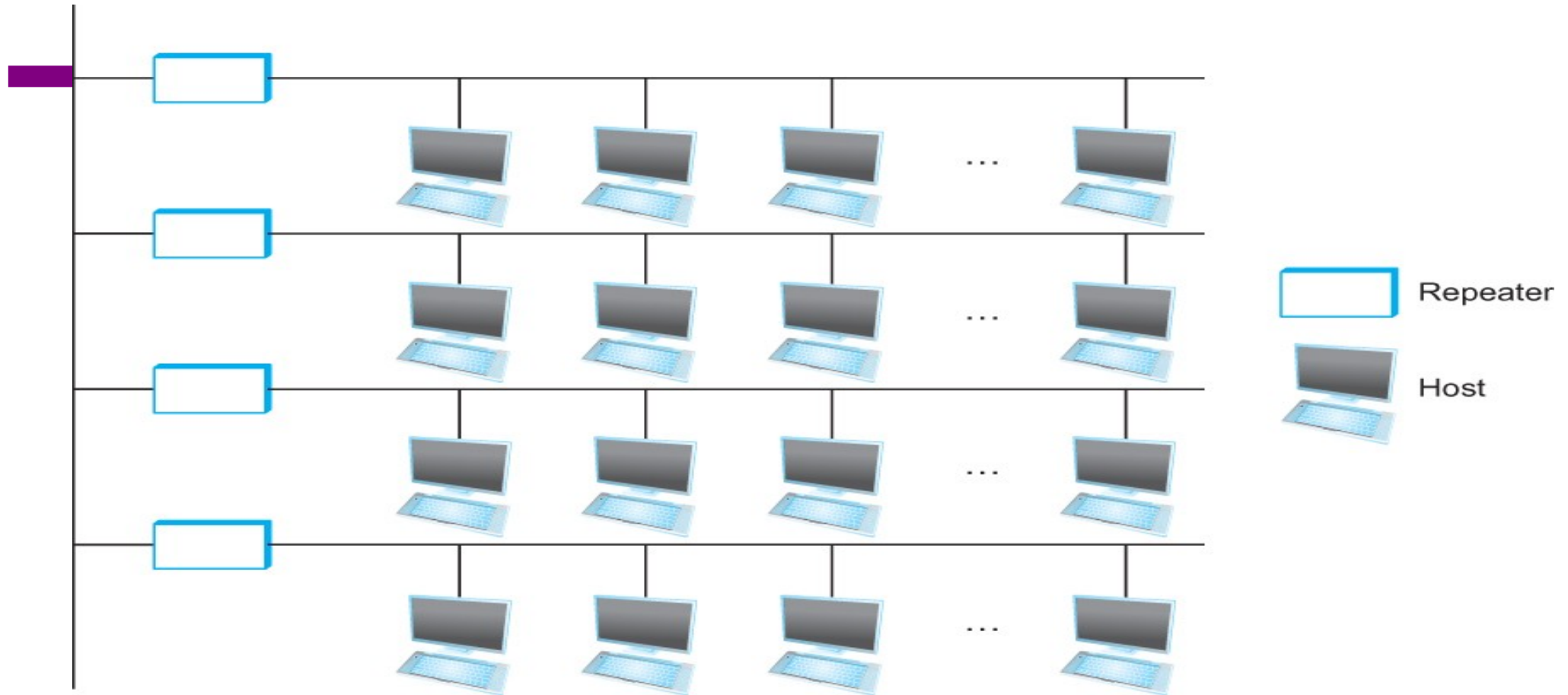

Ethernet repeater

Ethernet – Random Access

- How to allow many adaptors to send frames over the wire?
 - **Random access**
 - When you have data – send at Full channel rate!
 - No coordination needed.
- If collision happens
 - Detect
 - Recover
 - Retransmit

CSMA/CD – Listen first, talk later!

- CSMA – Carrier sense Multiple access
 - Listen if anyone is transmitting
 - Wait until carrier is free, do not interrupt others
 - **What is the carrier here?**
- CD – Collision Detection
 - If you hear anyone while talking, **collision, stop!**
 - Monitor signal strength at the adapter
 - Higher than normal = collision
- Random wait before retransmitting
 - **Why?**

CSMA/CD – Ethernet.

1) Carrier Sense

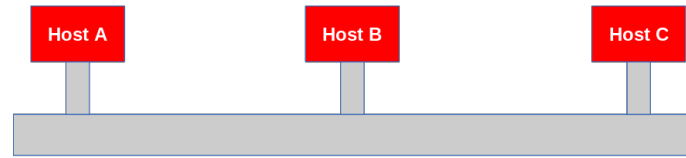

2) Multiple Access

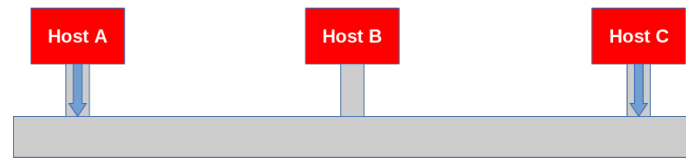

3) Collision

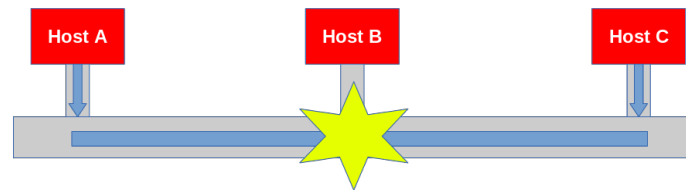

4) Collision Detection (Back off Algorithmus)

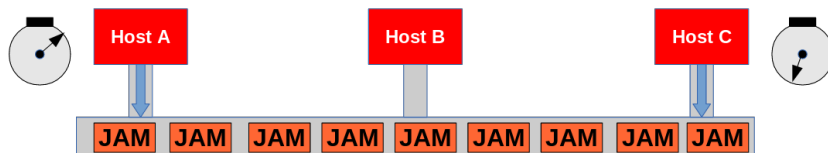

- CS – wait until idle
 - Channel idle – transmit
 - Channel busy – wait
- CD – listen while transmitting
 - No collision: transmission successful
 - Collision: abort, send jam signal (32bit special sequence)
- Wait random time
 - Try again
 - After m^{th} collision,
 $t = \text{random}(0, 2^m - 1)$,
 - Wait $t * 512$ bit times before retry

Ethernet Frame

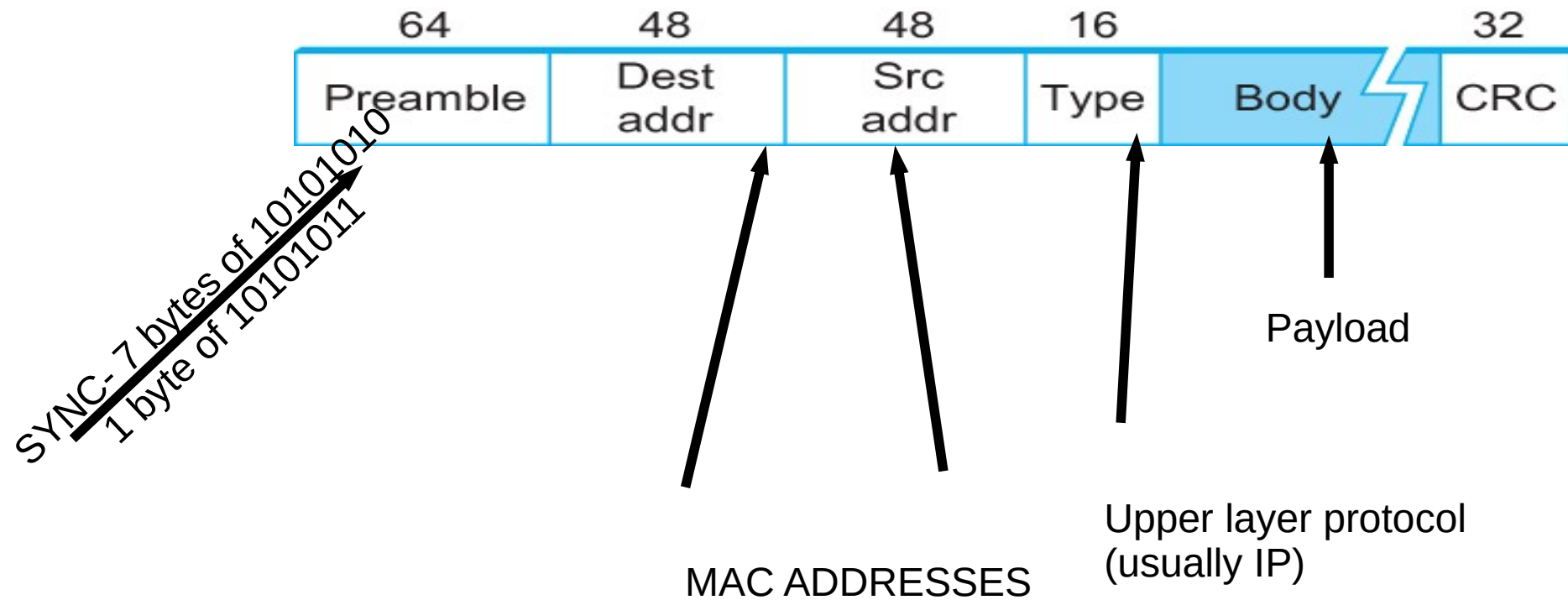

Access Protocol for Ethernet

- The algorithm is commonly called Ethernet's Media Access Control (MAC).
 - It is implemented in Hardware on the network adaptor.
- Frame format
 - Preamble (64bit): allows the receiver to synchronize with the signal (sequence of alternating 0s and 1s).
 - Host and Destination Address (48bit each).
 - Hardcoded
 - Packet type (16bit): acts as demux key to identify the higher level protocol.
 - Data (up to 1500 bytes)
 - Minimally a frame must contain at least 46 bytes of data.
 - Frame must be long enough to detect collision.
 - CRC (32bit)

Ethernet Transmitter Algorithm

- Once an adaptor has detected a collision, and stopped its transmission, it waits a certain amount of time and tries again.
- Each time the adaptor tries to transmit but fails, it doubles the amount of time it waits before trying again.
- This strategy of doubling the delay interval between each retransmission attempt is known as *Exponential Backoff*.

Ethernet Transmitter Algorithm

- The adaptor first delays either 0 or 51.2 μs , selected at random
- If this effort fails, it then waits 0, 51.2, 102.4, 153.6 μs (selected randomly) before trying again;
 - This is $k * 51.2$ for $k = 0, 1, 2, 3$
- After the third collision, it waits $k * 51.2$ for $k = 0 \dots 2^3 - 1$ (again selected at random).
- In general, the algorithm randomly selects a k between 0 and $2^n - 1$ and waits for $k * 51.2 \mu\text{s}$, where n is the number of collisions experienced so far.

Ethernet Transmitter Algorithm

- An adaptor may begin transmitting at/near the same time
 - Either because both found the line to be idle,
 - Or, both had been waiting for a busy line to become idle.
- Simultaneously transmitted frames collide
- Each sender can detect collisions (CDMA/CS)
 - **Detection MUST happen during transmission**
 - Each transmits a 32-bit jamming sequence
 - Will minimally send **96** bits (*runt* frame)
 - 64-bit preamble + 32-bit jamming sequence
 - Works if hosts are close to each other
 - Worst case: transmitter may need to send up to **512** bits
 - Every Ethernet frame must be at least 512 bits (64 bytes) long.
 - 14 bytes of header + 46 bytes of data + 4 bytes of CRC

Ethernet Transmitter Algorithm

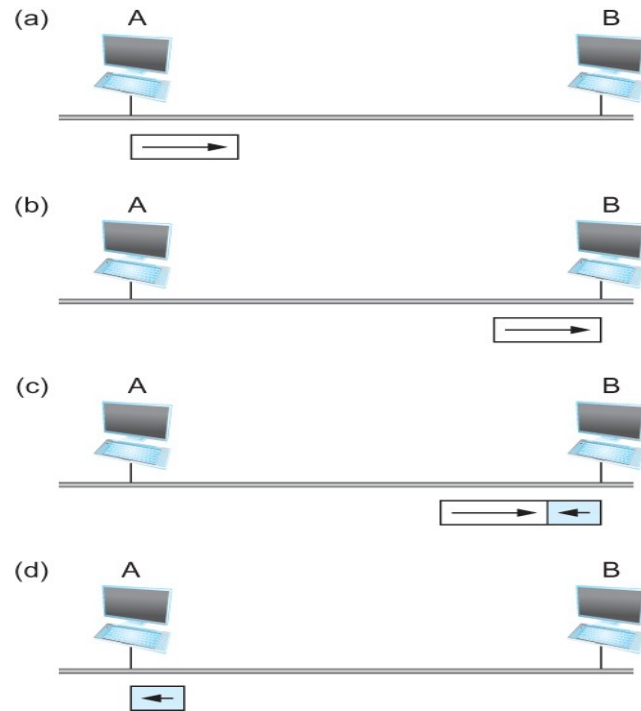

Worst-case scenario:

(a) A sends a frame at time t ;

(b) A's frame arrives at B at time $t + d$;

(c) B begins transmitting at time $t + d$,
collides with A's frame;

(d) B's runt (32-bit) frame arrives at A at time $t + 2d$.

(e) A is no longer transmitting – so, it does nothing!

Ethernet Minimum Frame Size

- Ethernet max length = 2500 meters
- RTT in worst case is $51.2 \mu\text{s}$, which corresponds to the transmission time of 512 bits
- Each ethernet frame **MUST** be at least 512 bits

Experience with Ethernet

- Ethernets work best under lightly loaded conditions.
 - Under heavy loads, too much of the network's capacity is wasted by collisions.
- Most Ethernets are far shorter than 2500m with a round-trip delay of closer to 5 μ s than 51.2 μ s.
- Ethernets are easy to administer and maintain.
 - There are no switches that can fail and no routing and configuration tables that have to be kept up-to-date.
 - Cable is cheap, and only other cost is the network adaptor on each host.

Wireless

- Wireless links transmit electromagnetic signals
 - Radio, microwave, infrared
- Wireless links all share the same “wire” (so to speak)
 - The challenge is to share it efficiently without unduly interfering with each other
 - Most of this sharing is accomplished by dividing the “wire” along the dimensions of frequency and space
- Exclusive use of a particular frequency in a particular geographic area may be allocated to an individual entity such as a corporation

Wireless Links

- Wireless technologies differ in a variety of dimensions
 - How much bandwidth they provide
 - How far apart the communication nodes can be

- Four prominent wireless technologies
 - Bluetooth
 - Wi-Fi (more formally known as 802.11)
 - WiMAX (802.16)
 - Cellular wireless (3/4/5G) – 6G anyone?

Wireless Links



	Bluetooth (802.15.1)	Wi-Fi (802.11)	3G Cellular
Typical link length	10 m	100 m	Tens of kilometers
Typical data rate	2 Mbps (shared)	54 Mbps (shared)	Hundreds of kbps (per connection)
Typical use	Link a peripheral to a computer	Link a computer to a wired base	Link a mobile phone to a wired tower
Wired technology analogy	USB	Ethernet	DSL

Overview of leading wireless technologies

Wireless Links - Infrastructure

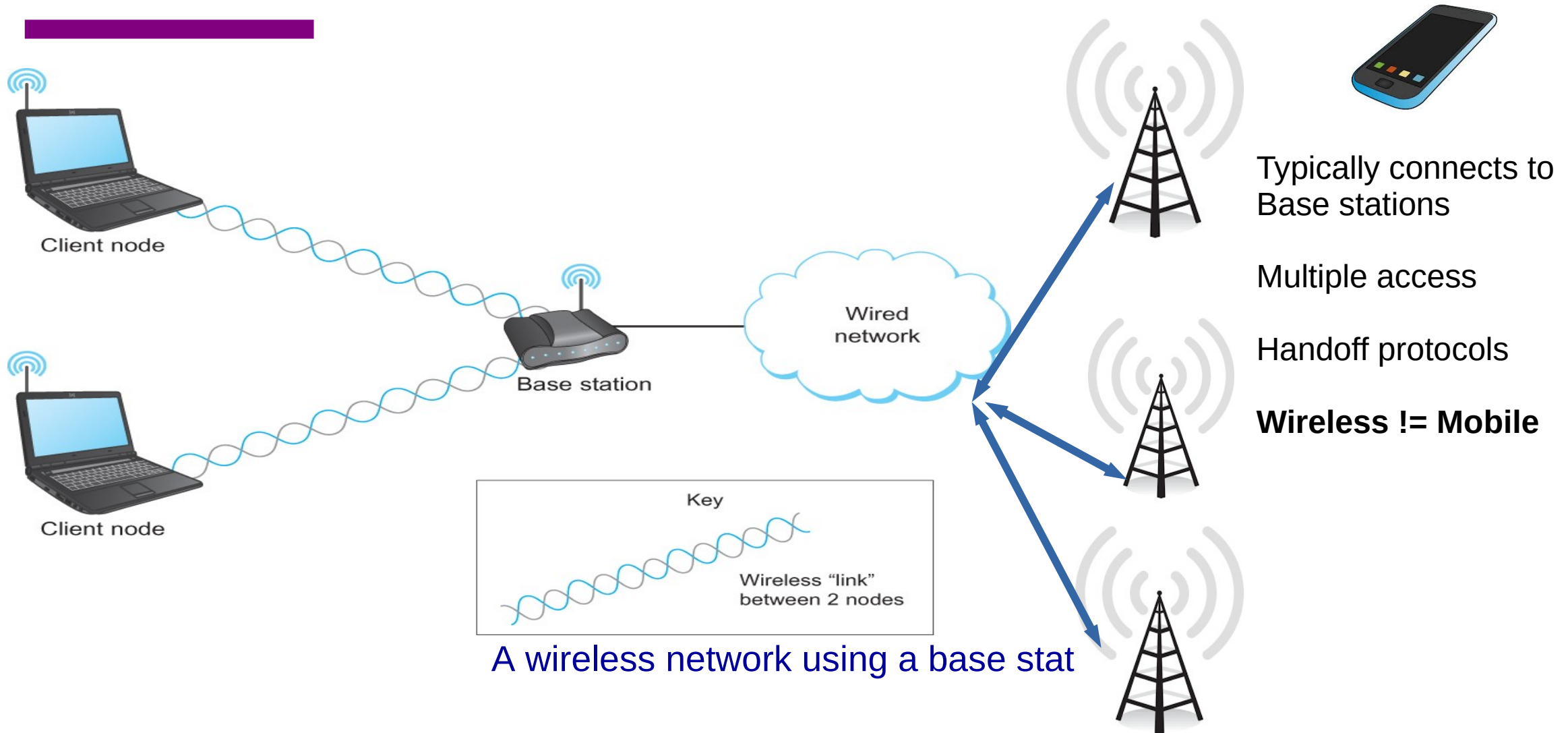

Wireless Links - Ad hoc

- Mesh or Ad-hoc network
 - Nodes are peers
 - Messages may be forwarded via a chain of peer nodes

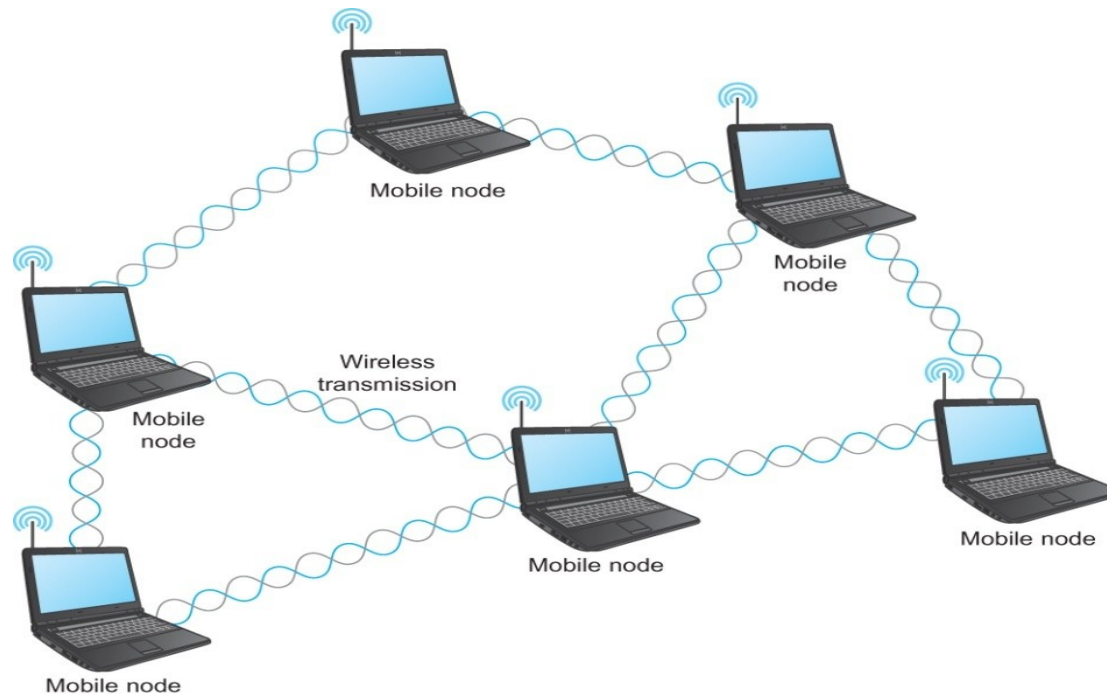

Wireless Links – Characteristics

- Difference from wired?
 - Decreased signal strength (radio signals travel through the atmosphere)
 - Interference (Other signals interfere, microwave, phones, each other)
 - Multipath and noise
 - Reflects of objects

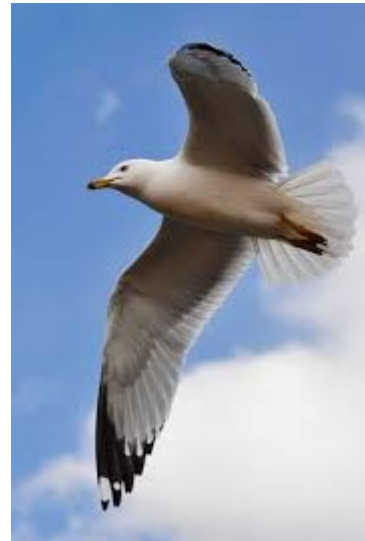

Can't hear you!!!!

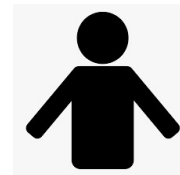

Wireless Links - other problems

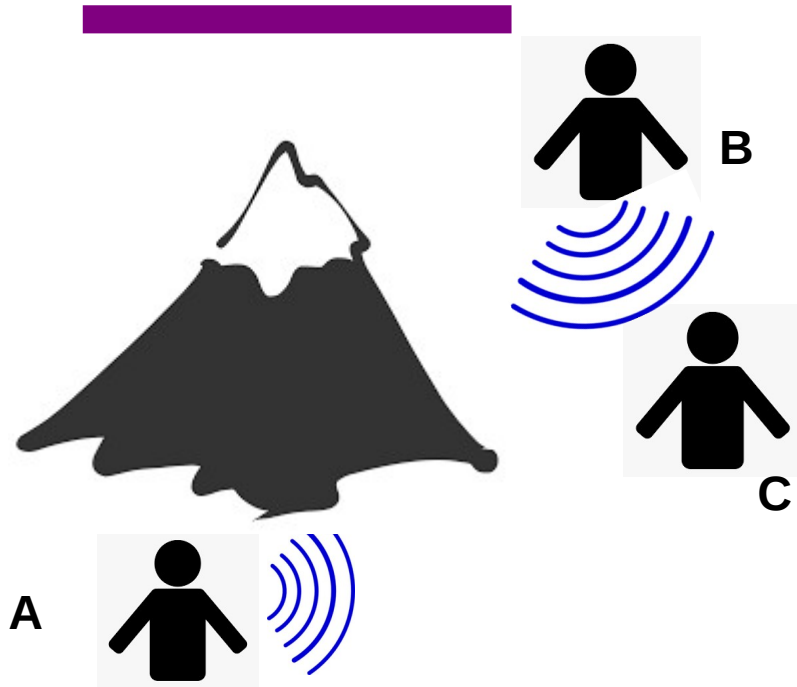

A and C can talk
B and C can talk
A and B can not!!!
Interference at B

Hidden terminal

Signal Fading

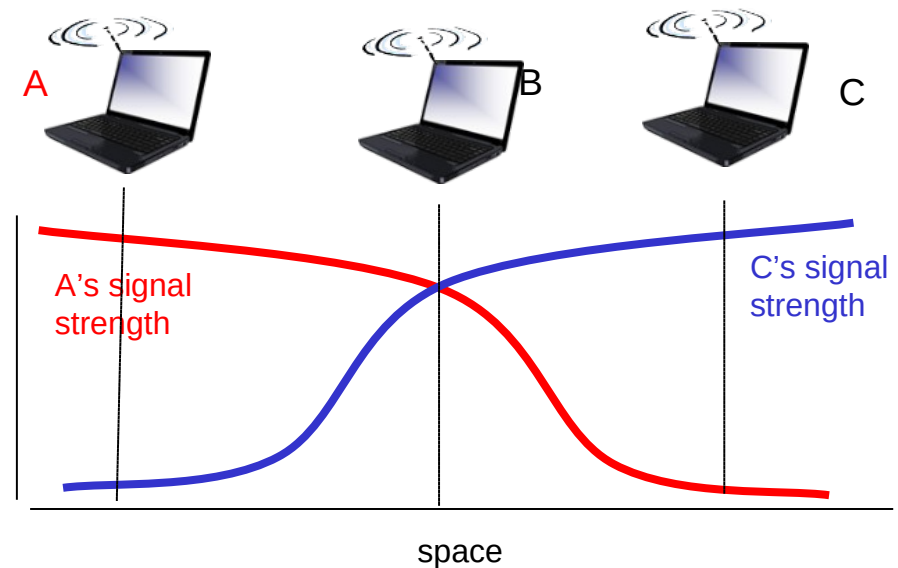

WiFi – 802.11 Wireless Lan

802.11 b

- 2.4-5 GHz unlicensed spectrum
- Divided into 11 (or 13) channels
- Widely deployed
- Uses base stations, 11Mbps

802.11 G

54Mbps

802.11 N

450Mbps

802.11 A/C

1.3 Gbps

All use base station or ac-hoc versions

All use CSMA/CA for multiple access

802.11 – CSMA/Collision Avoidance (CA)

- **802.11: no collision detection! Why?**
 - It won't work anyway, hidden node, signal fading
- **Avoid Collisions**
- **CSMA - sense before transmitting**

IEEE 802.11: Multiple Access

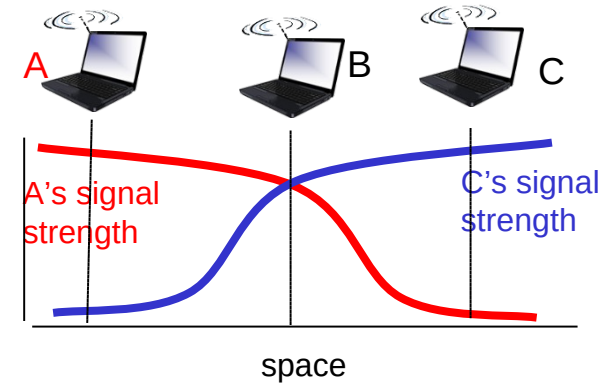

- Avoid collisions: 2+ nodes transmitting at same time
- 802.11: CSMA - sense before transmitting
 - don't collide with ongoing transmission by other node
- 802.11: *no* collision detection!
 - difficult to receive (sense collisions) when transmitting due to weak received signals (fading)
 - can't sense all collisions in any case: hidden terminal, fading
 - goal: *avoid collisions*: CSMA/C(ollision)A(voidance)

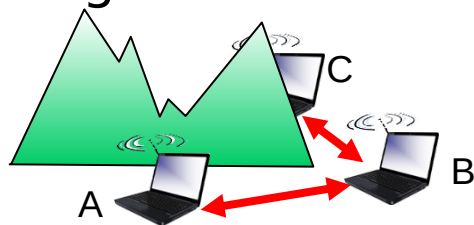

IEEE 802.11 MAC Protocol: CSMA/CA

802.11 sender

- 1 if sense channel idle for **DIFS** then
transmit entire frame (no CD)
- 2 if sense channel busy then
start random backoff time
timer counts down while channel idle
transmit when timer expires
if no ACK, increase random backoff interval, repeat 2

802.11 receiver

- if frame received OK
return ACK after **SIFS** (ACK needed due to hidden terminal problem)

$$\text{DIFS} = \text{SIFS} + (2 * \text{Slot time})$$

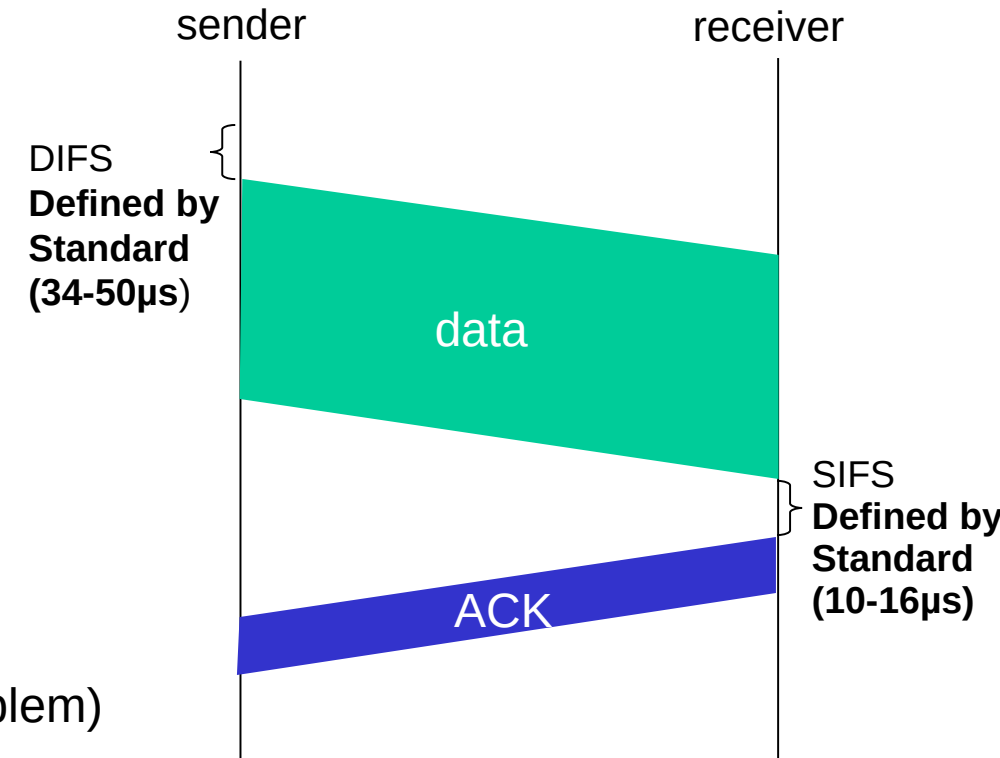

Avoiding collisions – Reserve before Send

idea: allow sender to “reserve” channel rather than random access

- sender first transmits *small* request-to-send (RTS) packets to BS using CSMA
 - RTSs may still collide with each other (but they’re short)
- BS broadcasts clear-to-send CTS in response to RTS
- CTS heard by all nodes
 - sender transmits data frame
 - other stations defer transmissions

*avoid data frame collisions completely
using small reservation packets!*

Collision Avoidance: RTS-CTS exchange

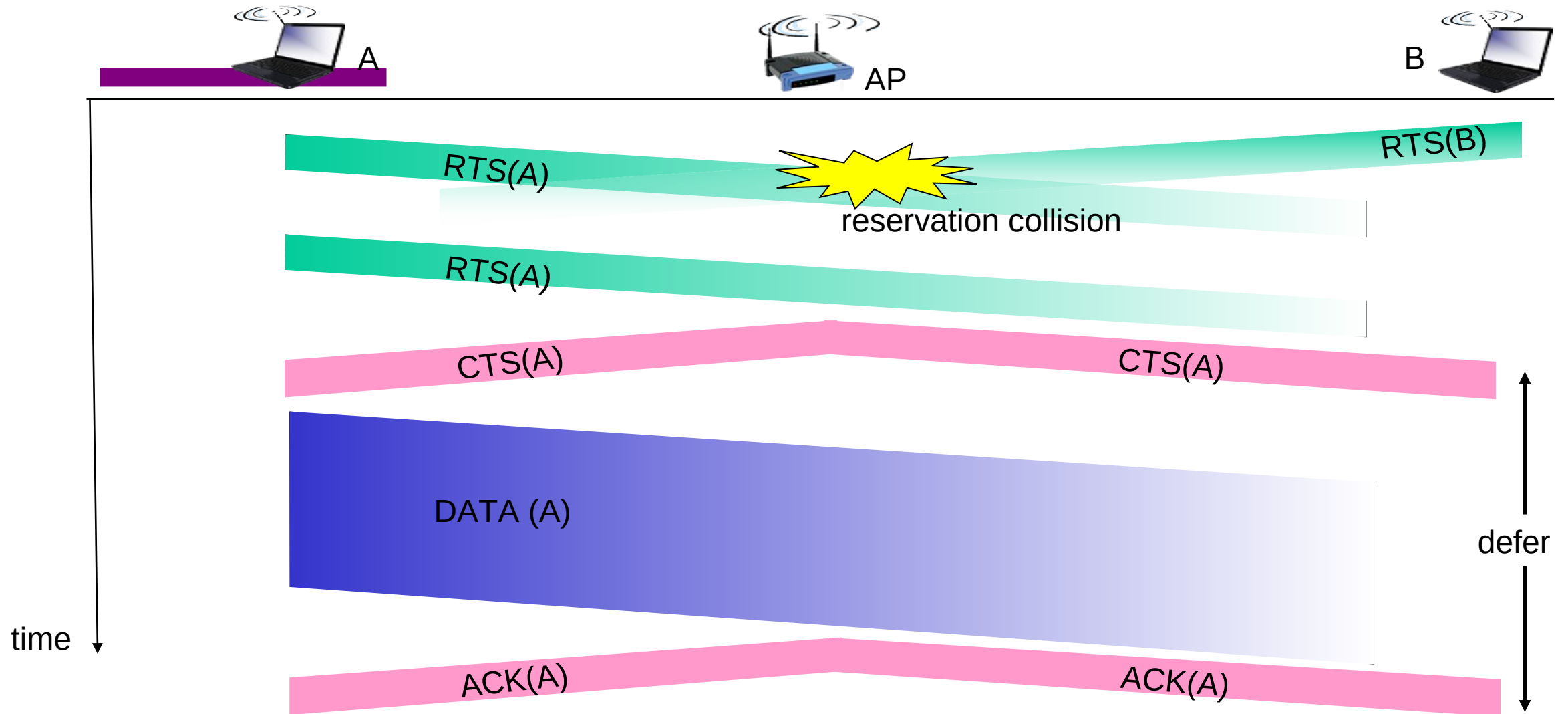

802.11 frame: Addressing

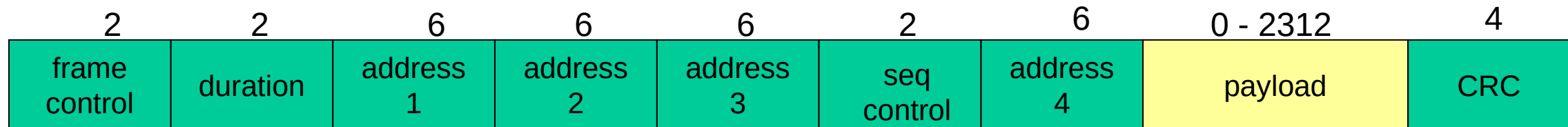

Address 1: MAC address of wireless host or AP to receive this frame

Address 2: MAC address of wireless host or AP transmitting this frame

Address 3: MAC address of router interface to which AP is attached

Address 4: used only in ad hoc mode

802.11 frame: More

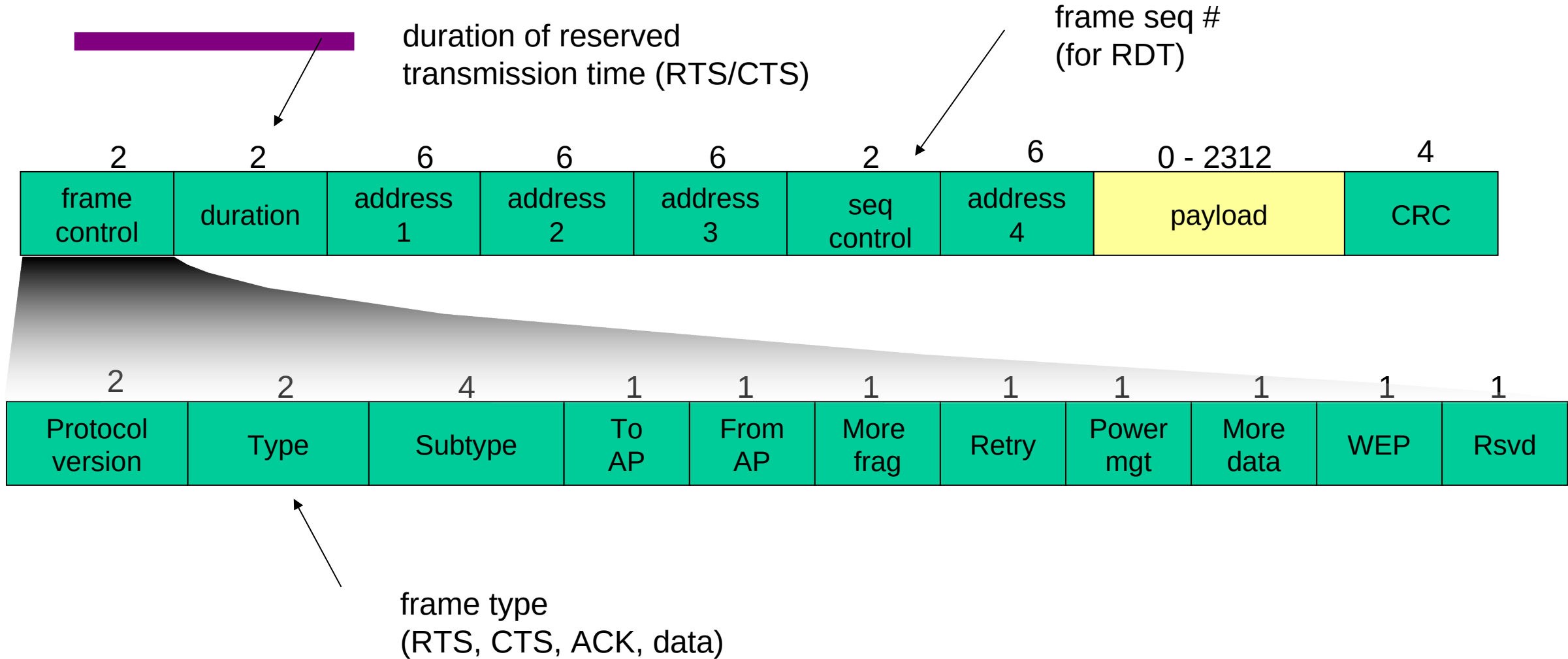



Link Layer Recap – All this for a cat picture

