

CSC4200 – Homework 3 (Each question is worth 10 points)
Due – Friday, March 4th, 10PM CST

1. Construct the forwarding table for Switch 3 based on the following diagram.

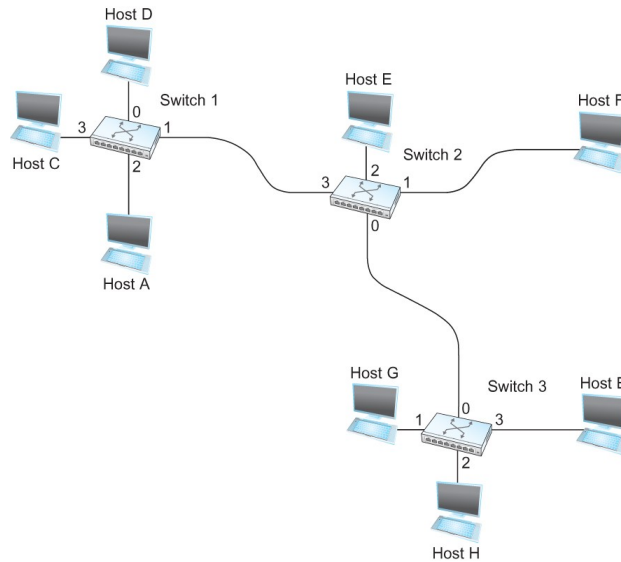

2. Given the LAN below, which ports are *not* selected by the spanning tree algorithm?

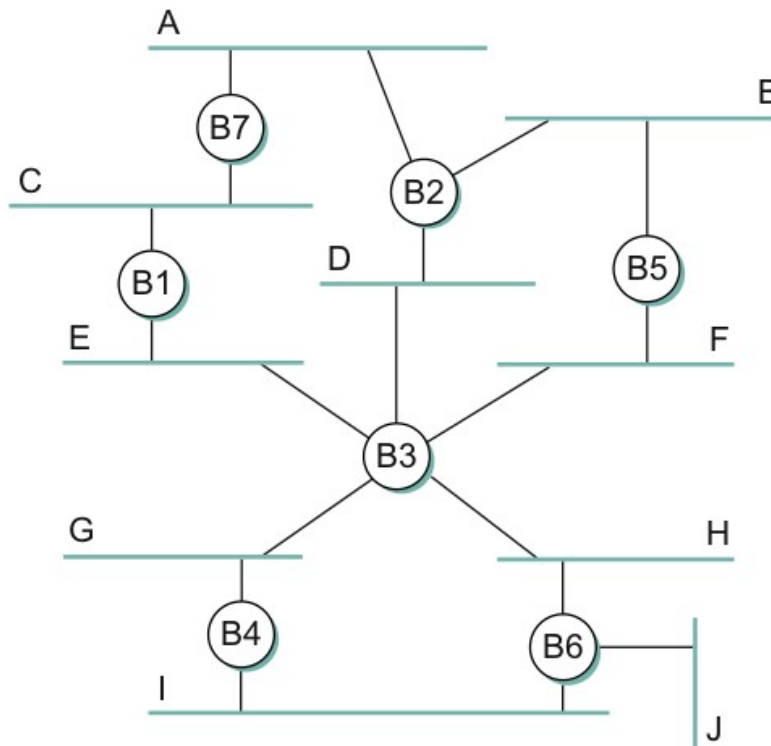

3. How are VLANs different from normal LANs? Why do we use VLANs?

4. What aspect of IP addresses makes it necessary to have one address per network interface, rather than just one per host? In light of your answer, why does IP tolerate point-to-point interfaces that have nonunique addresses or no addresses?

5. Suppose a TCP message that contains 1024 bytes of data and 20 bytes of TCP header is passed to IP for delivery across two networks interconnected by a router (i.e., it travels from the source host to a router to the destination host). The first network has an MTU of 1024 bytes; the second has an MTU of 576 bytes. Each network's MTU gives the size of the largest IP datagram that can be carried in a link-layer frame. Give the sizes and offsets of the sequence of fragments delivered to the network layer at the destination host. Assume all IP headers are 20 bytes.

6. Why do you think IPv4 has fragment reassembly done at the endpoint, rather than at the next router?

7. Having ARP table entries time out after 10 to 15 minutes is an attempt at a reasonable compromise. Briefly describe the problems that can occur if the timeout value is too small or too large.

8. What is the network address, subnet mask, and broadcast address for 192.168.1.0/11? What is the first and the last IP address in the sequence?

9. An organization has been assigned the prefix 212.1.1/24 (class C) and wants to form subnets for four departments, with hosts as follows:

A - 75 hosts

B - 35 hosts

C - 20 hosts

D - 18 hosts

There are 148 hosts in all.

(a) Give a possible arrangement of subnet masks to make this possible.

(b) Suggest what the organization might do if department D grows to 32 hosts

10. For the network below, show the distance vector table.

